

PN	DESCRIPTION
4042SA	WITHOUT LIGHT
4042SAL	WITH LIGHT

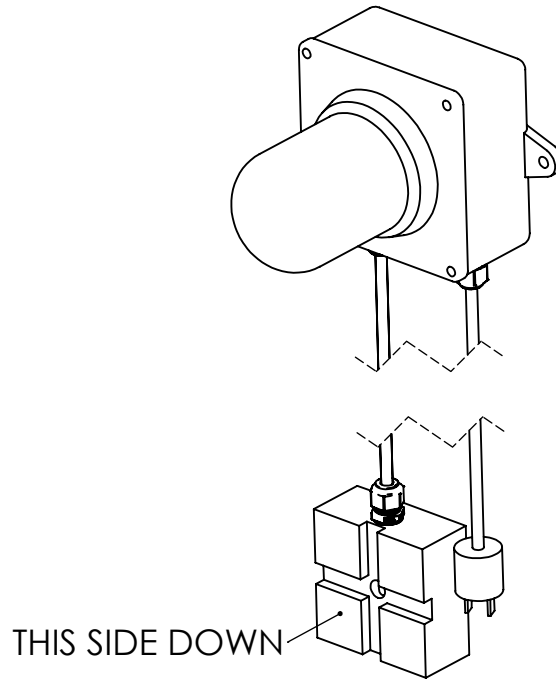

NOTES:  
 6'/1.8m POWER CORD  
 20'/6.1m SENSOR CORD

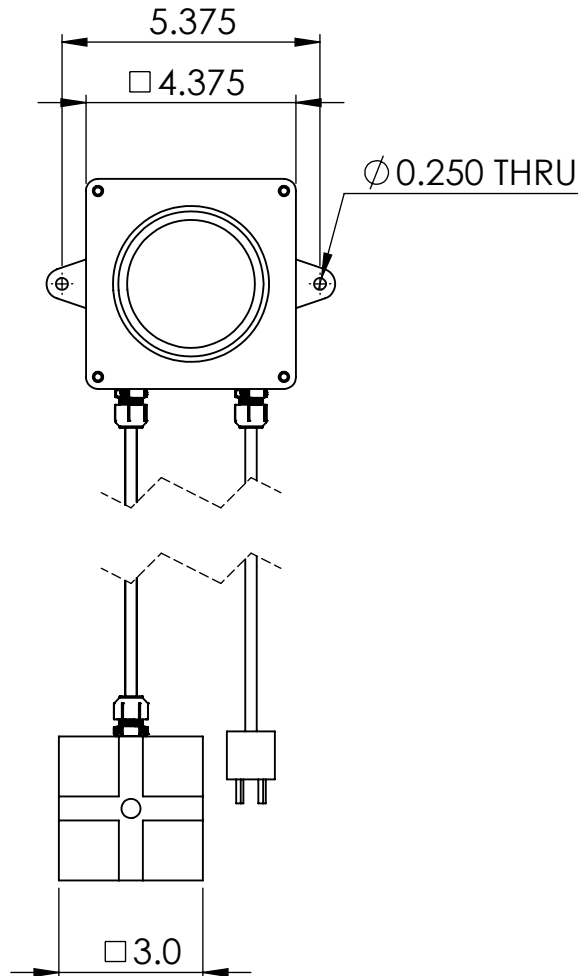

53 Apple Tree Lane  
 P.O. Box 365  
 Plumsteadville, PA 18949  
 Toll Free: (800) 257-5911  
 Phone: (215) 766-2670  
 Fax: (215) 766-2672  
 E-Mail: info@scaletronscales.com  
 Website: www.scaletronscales.com

**NOTICE**

THE INFORMATION CONTAINED IN THIS DRAWING IS THE SOLE PROPERTY OF SCALETRON INDUSTRIES LTD. ANY REPRODUCTION IN PART OR AS A WHOLE WITHOUT THE WRITTEN PERMISSION OF SCALETRON INDUSTRIES LTD IS PROHIBITED.

**MODEL 4042SA or SAL**  
 LEAK DETECTING SPILL ALARM

REV

CBC 12/13/2021